



## **Diode Laser uses in Skin Tightening**

Dr. Mohammad Saleem <sup>\*1</sup>, Dr. Dheyaa Al-Alkharsa <sup>2</sup>, Dr. Areej Abdulhamid Farhat <sup>3</sup>,  
Dr. Ahmad Jamal Bany Younis <sup>4</sup>, Wayne Selting <sup>5</sup>

- 1. Dentist and Oral Maxillofacial Surgeon, B.D.S, Msc, ABLS.*
- 2. Dentist Germany, USA.*
- 3. Bachelor of dental surgery, Master's in Public Health Education at USF and Registered Dental Hygienist in Tampa Florida.*
- 4. BDS Cairo University.*
- 5. Department of Surgical Science and integrated Diagnostics, University of Genoa, Largo R. Benzi 10-16132 Genoa Italy.*

**\*Correspondence to:** Dr. Mohammad Saleem, Dentist and Oral Maxillofacial Surgeon, B.D.S, Msc, ABLS.

### **Copyright**

© 2024 **Dr. Mohammad Saleem.** This is an open access article distributed under the Creative Commons Attribution License, which permits unrestricted use, distribution, and reproduction in any medium, provided the original work is properly cited.

Received: 11 March 2024

Published: 01 April 2024

### **Abstract**

*Diode Laser is a modern non-invasive therapeutic method used for skin tightening. It can be successfully employed in several medical fields including dermatology, urology, ophthalmology, cardiology, dentistry, and immunology. Numerous authors, therefore, have studied this technique in order to improve its efficacy. Significant advancement has been achieved with regard to Diode Laser. Substantial progress was also obtained with respect to Diode for the treatment of skin lesions with emphasis on cutaneous precancerous lesions. This report will explain how Diode laser is used in skin tightening and what is the best technique that will give me the best skin tightening result. Also I will talk about laser biophysics and skin anatomy.*

**Keyword:** *Diode, mid infrared, Laser, Skin, Rejuvenation*

### **Introduction**

Light is a form of electromagnetic energy that exists as a particle and that travels in waves at a constant velocity. Unit of this radiant energy is called a photon.

The waves of photons travel at the speed of light and can be defined by two basic properties: amplitude and wavelength.

Amplitude is defined as the vertical height of the wave from the zero axis to its peak as it moves around that axis.

The second property of a wave is wavelength ( $\lambda$ ), the horizontal distance between any two corresponding points on the wave.

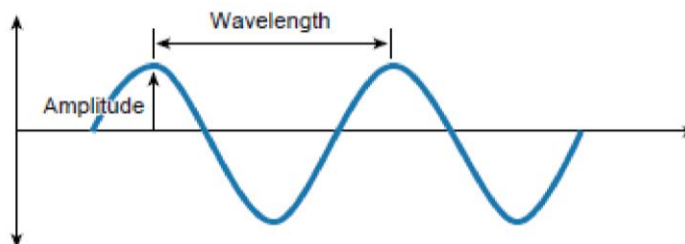

## What is a Laser?

The word laser is an acronym for light amplification by stimulated emission of radiation. Laser is not the same as normal light it has a specific characteristic :

**Monochromatic:** It is generated as a beam of a single color, which is invisible if its wavelength is outside of the visible part of the spectrum.

Coherent, or identical in physical size and shape. Thus the amplitude and frequency of all of the waves of photons are identical. This coherence results in the production of a specific form of focused electromagnetic energy.

Collimated (produced with all waves parallel to each other) over a long distance, but once the laser beam enters certain delivery systems such as optical fibers or tips.

## Amplification

Amplification is the part of this process that occurs inside the laserCavity , this laser cavity composed of

Active medium:Lasers are generically named for the material of the active medium, which can be

- 1) A container of gas, such as a canister of carbon dioxide (CO<sub>2</sub>) gas in a CO<sub>2</sub> laser;
- 2) A solid crystal, such as that in an erbium-doped YAG (Er:YAG) laser;
- 3) A solid-state semiconductor, such as the semiconductors found in diode lasers;
- 4) A liquid, such as that used in some medical laser devices

Pumping mechanism drives energy into the active medium.

Optical resonator is composed of two mirrors, one at each end of the optical cavity, placed parallel to each other; or in the case of a semiconductor diode laser, two polished surfaces at each end. These

---

mirrors or polished surfaces act as optical resonators, reflecting the waves back and forth, and help to collimate and amplify the developing beam

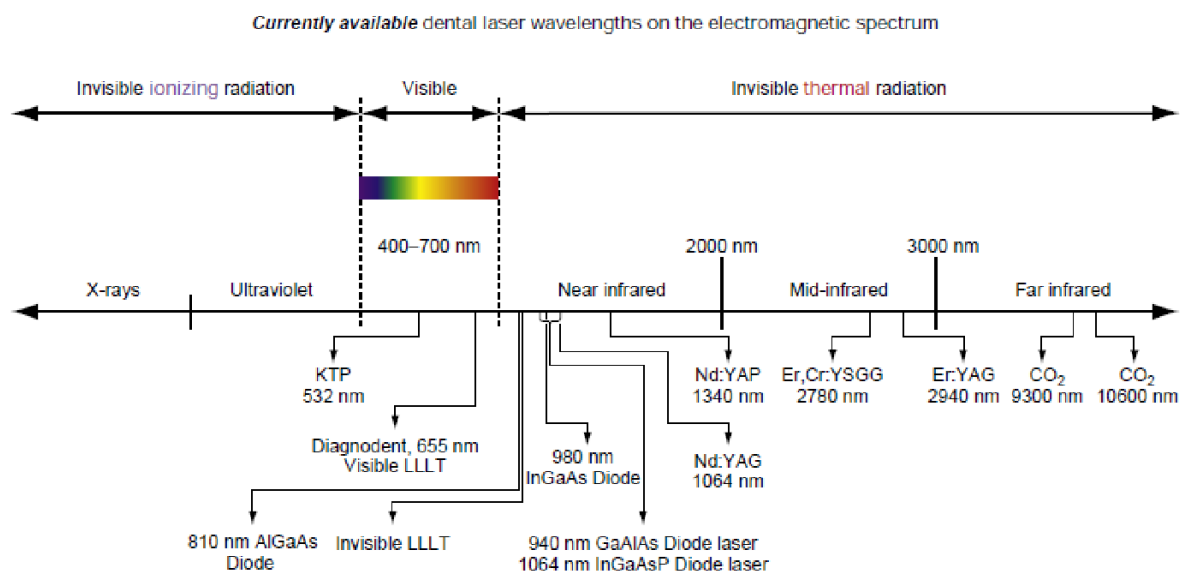
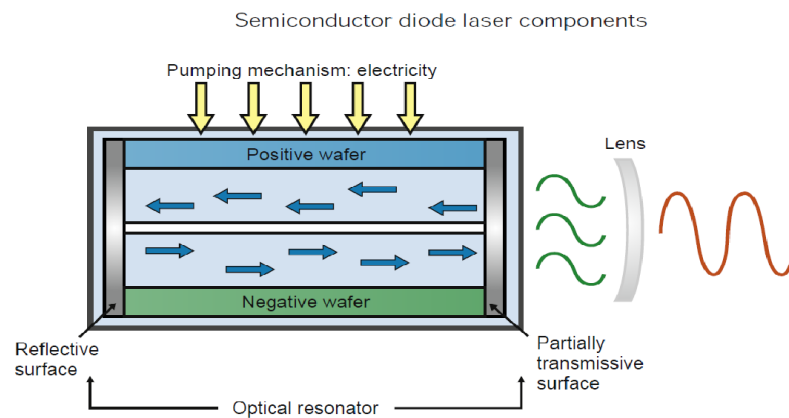

### Laser Delivery Systems

Laser energy should be delivered to the surgical site by a method that is ergonomic and precise.8 Shorter-wavelength instruments.

Flexible fiberoptic systems with bare glass fibers that deliver the laser energy to the target tissue



Semiflexible hollow waveguides

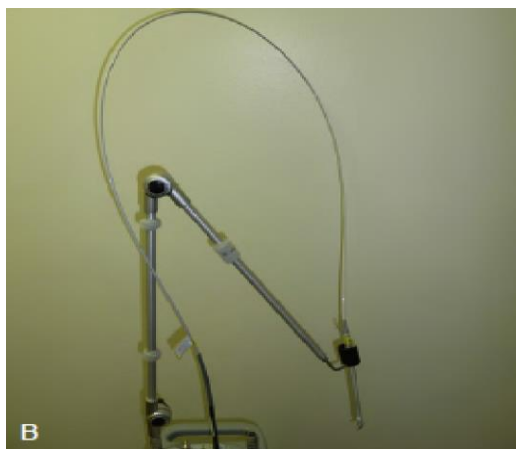

Articulated arms



Some of these systems employ small quartz or sapphire tips that attach to the laser device for contact with target tissue; others employ noncontact tips



### Emission Modes

1. **Continuous-wave mode**, in which the beam is emitted at only one power level for as long as the operator depresses the foot switch.
2. **Gated-pulse mode**, characterized by periodic alternations of the laser energy, similar to a blinking light. This mode is achieved by the opening and closing of a mechanical shutter in front of the beam path of a continuous-wave emission
3. **Free-running pulsed mode**

This emission is unique in that large peak energies of laser light are emitted usually for microseconds, followed by a relatively long time in which the laser is off. For example, with a free-running pulsed laser with pulse duration of 100  $\mu$ sec and pulses delivered at 10 per second (10 Hz), the energy at the surgical site is present for 0.01% of a second and absent for the remaining 99.99% of that second.

### Laser Effects on Tissue

- Reflection Simply the beam being redirected off the surface, with no effect on the target tissue.

- Absorption of the laser energy by the intended target tissue usually is the most desirable effect.
- Transmission Of the laser energy directly through the tissue, with no effect on the target tissue
- Scattering Of the laser light, which weakens the intended energy

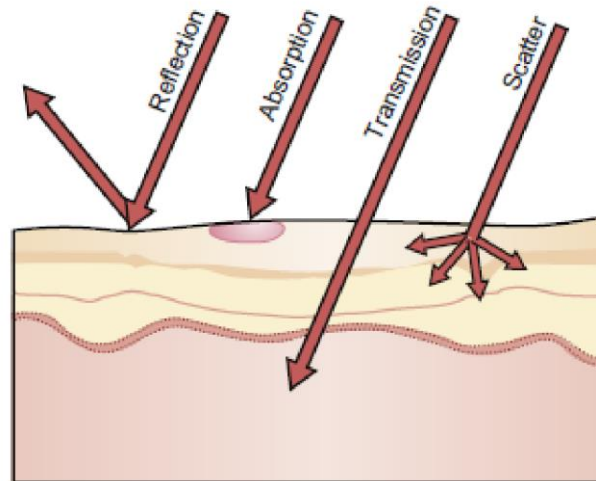

### **Laser-tissue interaction:**

Photothermal, which means the laser energy, is transformed into heat. The three primary photothermal laser-tissue interactions are incision/ excision, ablation/vaporization, and hemostasis/coagulation

1. A laser beam in focus with a small spot size is used for incision/excision procedures
2. A laser beam with a wider spot size will interact with the tissue over a wider area, but more superficially, producing a surface ablation
3. A laser beam out of focus will produce hemostasis/ coagulation

Photochemical effects occur when the laser is used to stimulate chemical reactions, such as the curing of composite resin by an argon laser.

**Photobiostimulation:** A laser can be used in a nonsurgical mode for more rapid wound healing, pain relief, increased collagen growth, and a general anti-inflammatory effect.

The photoacoustic effect of laser light. This process often is called spallation. The pulse of laser energy on hard dentinal and osseous tissues can produce a shock wave

## Tissue Temperature

Most laser actions produce heat for the target tissue

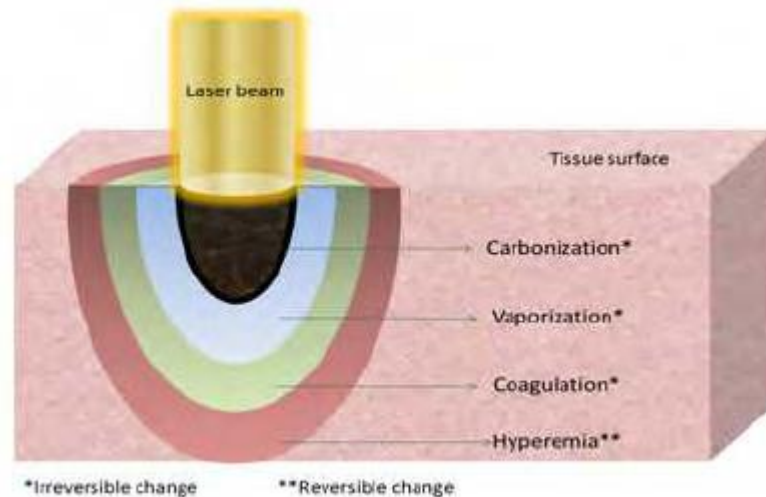

## Laser-tissue interaction – thermal

Thermal effects of laser radiation (raised temperature in tissue)

Temperature	Biological effect
37° C	Normal
45° C	Hyperthermia
50° C	Reduction in enzyme activity, cell immobility
60° C	Denaturation of proteins and collagen, coagulation
80° C	Permeabilization of membranes
100° C	Vaporization, thermal decomposition (ablation)
> 100° C	Carbonization
> 300° C	Melting

Note that protein and collagen denature at around 60° C  
Heating tissue at 60° C can lead to cell necrosis - can be used to kill cancer cells

Laser emission modes play an important role in increasing the tissue temperature. The important principle of any laser emission mode is that the light energy strikes the tissue for a certain length of time, producing a thermal interaction.<sup>16</sup> If the laser is used in a pulsed mode, the targeted tissue may have time to cool before the next pulse of laser energy is emitted.

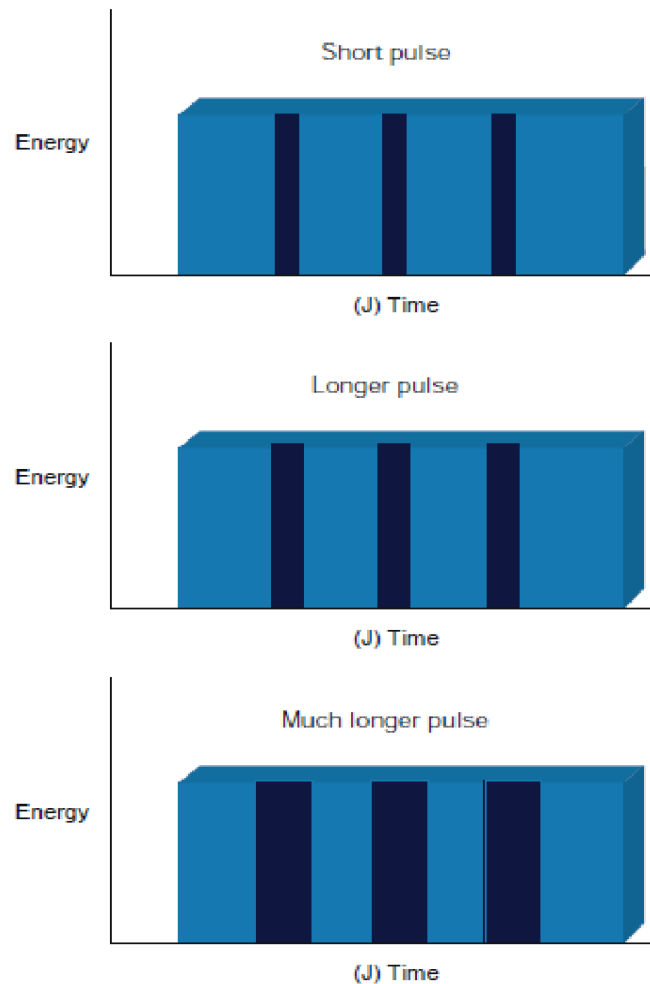

Various pulse parameters

### Absorption of Laser Energy by Dental Tissues

Different laser wavelengths have different absorption coefficients, with the primary oral tissue components of water pigment, blood constituents, and minerals (Figure 2-27). Laser energy can therefore be reflected, absorbed, transmitted, or scattered, depending on the composition of the target tissue. The primary absorbers of specific laser energy are called chromophores

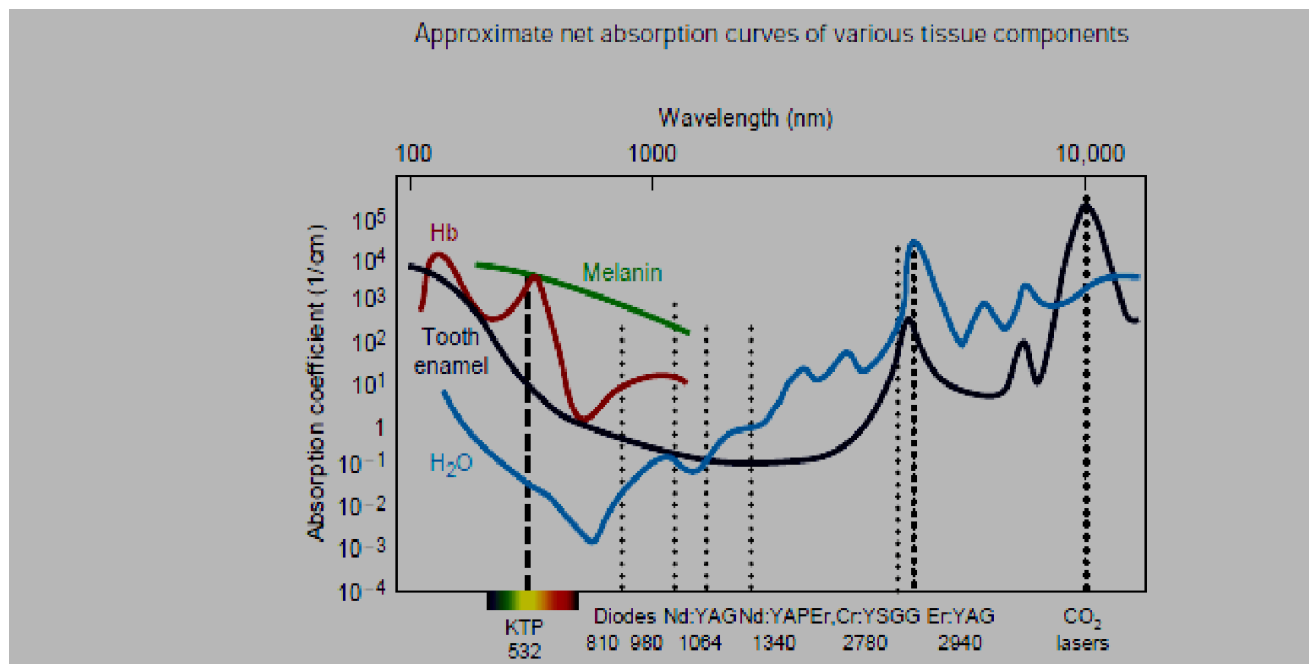

Each laser wavelength will affect the interrelated components of the target tissue: water content, color of the tissue, vascularity, and chemical composition. The diameter of the laser spot on the tissue, or spot size, whether delivered in contact or noncontact with the tissue, will create a certain amount of energy per square millimeter of tissue. This is called energy density. the smaller the spot size, the greater the fluence For example, a beam diameter of 200  $\mu\text{m}$ , compared with a beam diameter of 300  $\mu\text{m}$  at the same output setting, will have more than twice as much energy density. Also The amount of time during which the beam is allowed to strike the target tissue will affect the rate of tissue. There are many other factors that affect the laser tissue temperature like Using a water or air spray can cool the tissue, which would affect the rate of vaporization , Repetition rate of the pulsed-laser emission mode and Hand speed: the speed of moving the laser through the tissue.

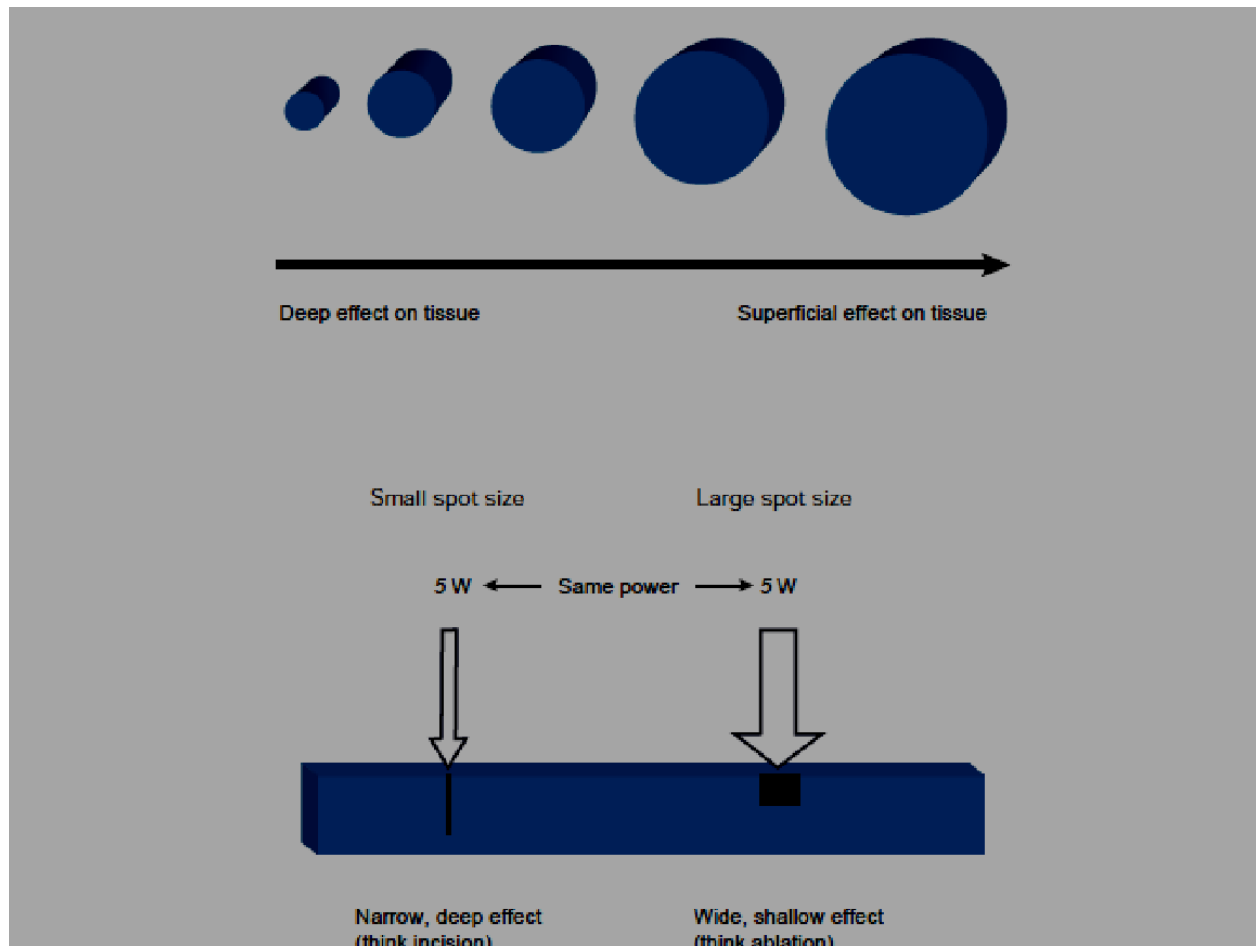

Graphic representation of the relationship between spot size and fluence. The same wavelength and power were used but the spot size was changed. On the left, the incision is narrow and deep with a smaller spot size; on the right, the incision is wide and shallow with a larger spot size.

### Laser Safety

- The Safety in all laser application is very important for all medical practitioners and also for patients
- The patient and all members of the surgical team must wear appropriate protective eyewear when the laser is operating, to prevent damage from any reflected or accidental direct energy exposure.

- The surgical environment must have a warning sign posted, with limited access to the treatment room
- High-volume suction must be used to evacuate the plume formed by tissue ablation, and the normal infection protocol must be followed.
- Masks must be of appropriate filtering capacity to prevent inhalation of laser plume which may contain particulate organic and inorganic matter (e.g., viruses, toxic gases, chemicals) and may be infectious and/or carcinogenic.

### **Laser penetration Depth:**

Penetration depth plays a very important role in Laser tissue or skin interaction and this depth will be affected by two important factors:

First one is wavelength and its absorption or interaction with chlorophorm for example

In diode Laser it has a high absorption coefficient with hemoglobin and melanin that means if this chemical agent is found in the tissue it will decrease its penetration.

The second one is power density or intensity also there is positive relationship between the penetration and the power density that means when we increase the power , frequency or surface area we will increase the penetration depth

And this is very important when we will work in the skin, we must understand the what we need to treat we need to make invasive treatment same like ablation or incision

In this case we need to increase the power and we automatically we will increase the penetration depth

Or we need to do noninvasive treatment we will decrease the power density and decrease the penetration depth.

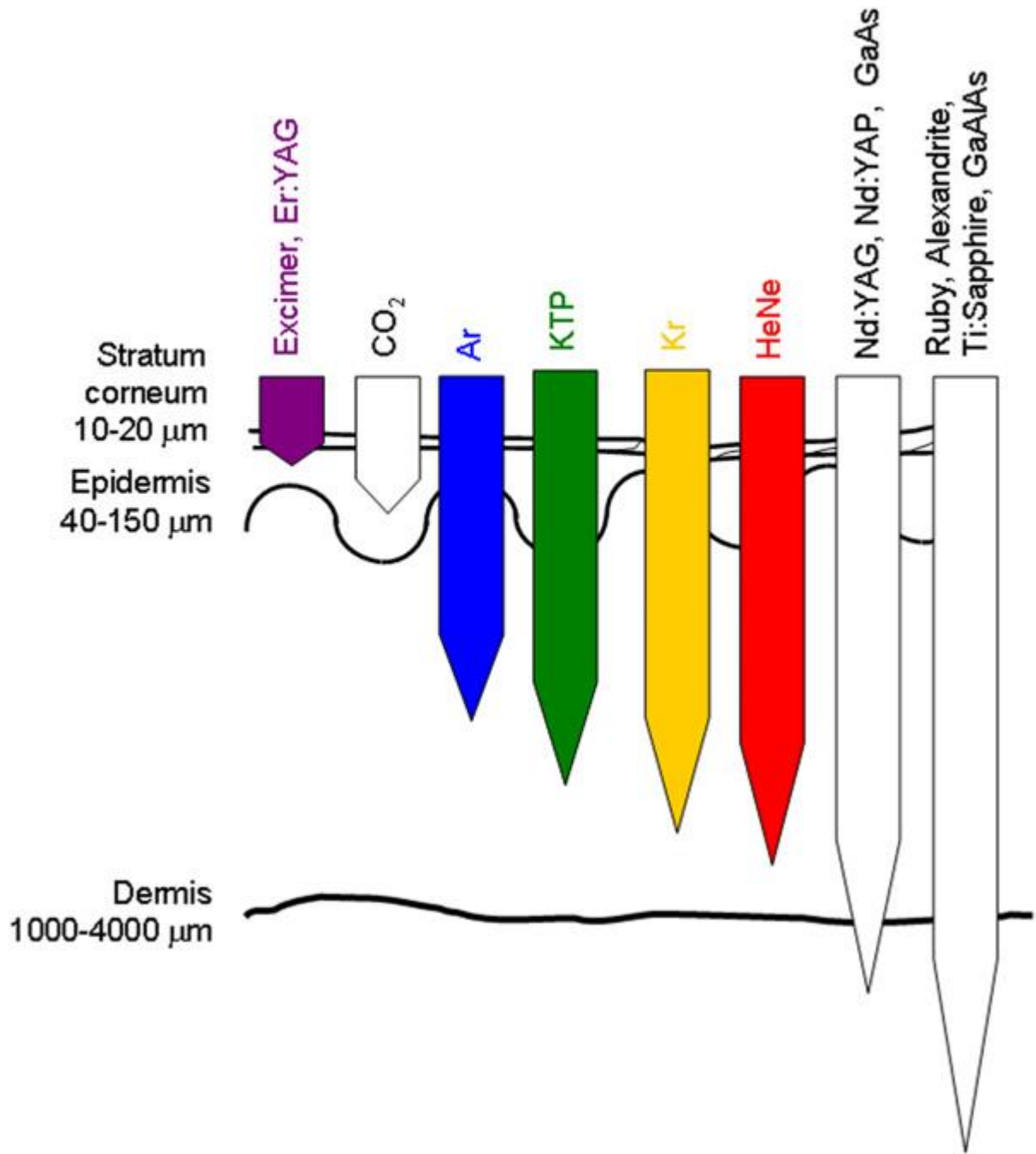

(a) Estimated penetration depth in bloodless, unpigmented tissue (see [15]) (solid [blue]line). The open circles indicate some common medical lasers. (b) Penetration depth of some common medical lasers in human skin tissue

## Diode lasers

Bands in semiconductors replace the discrete gap between different atomic energy levels, which is used in most other lasers. An electron excited into the conduction band of semiconductor can recombine with a positive hole in the valence band and emit a photon with an energy corresponding to the band gap energy. This is the reverse process of that taking place in a solar cell. Diode lasers are very efficient and reliable, and will probably lead to a silent revolution in medical applications. Powerful ones, with fluence rates up to more than 50W, are being constructed. Such lasers can act via a number of tissue reactions, such as hyperthermia, coagulation and evaporation. Atypical example is the GaAs laser at 904 nm. By substituting aluminium for gallium in the lattice ( $Ga_{1-x}Al_xAs$ ) the band gap will be increased, and the emission wavelength reduced accordingly. Typical commercially available diodes are AlGaAs diode at 805 nm wavelength. Larger wavelength can be obtained with In substitution, e.g. InGaAs at 1000 nm wavelength. Percutaneous laser disc decompression (PLDD) with the latter

Laser seems to be an efficient method for the treatment of thoracic disc disorders Diode lasers can be used as excitation sources for other lasers. Wavelengths from UV to infrared can be obtained. Fluorescence diagnostics and PDT are typical application fields .

### Advantages of Laser therapy in medicine :

1. Minimal collateral effects result in decreased tissue damage, thereby enhancing healing .
2. Patient comfort can be enhanced.
3. Hemostasis and coagulation typically are readily achieved, making the laser essential for medically compromised patients.
4. can be performed with the use of topical anesthesia only.
5. The concept of minimally invasive can be achieved.
6. It Is safe to use if the operator adheres to protocols.

## Human Skin:

The skin is the largest organ in the body with a total 20 square feet. The functions of the skin are the protection, sensation and save body temperature[16]. The skin is primarily made up of three layers. The upper layer is the epidermis, the layer below the epidermis is the dermis, and the third and deepest layer is the subcutaneous tissue[17]. The epidermis, the outermost layer of skin, provides a waterproof barrier and contributes to skin tone[18] as given in Figure.3

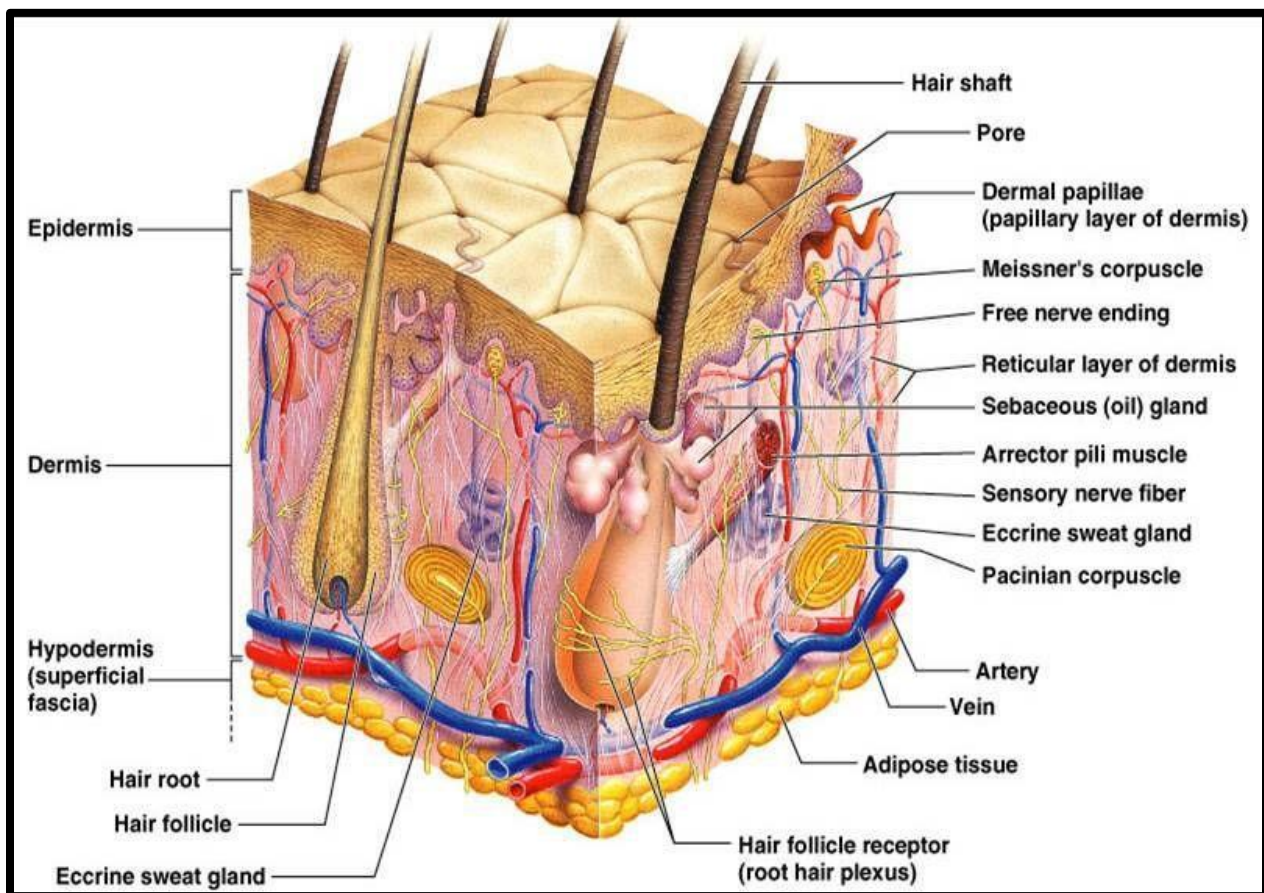

**Figure.3:** Anatomy of the Skin

## Epidermis:

- The epidermis is the outer layer of the skin, defined as a stratified squamous epithelium, primarily comprising keratinocytes in progressive stages of differentiation. Keratinocytes produce the protein keratin and are the major building blocks (cells) of the epidermis[20].

As the epidermis is avascular (contains no blood vessels).It is entirely dependent on the underlying dermis for nutrient delivery and waste disposal through the basement membrane.The physical and biological barrier to the external environment, preventing, penetration by irritants and allergens[21].It prevents the loss of water and maintains internal homeostasis The epidermis is composed of layers;Stratum corneum(horny layer);Stratum lucidum (only found in thick skin – that is, the palms of the hands, the soles of the feet and the digits);Stratum granulosum (granular layer);Stratum spinosum (prickle cell layer);Stratum basale (germinative layer)[22].

**Dermis:**

- The dermis forms the inner layer of the skin and is much thicker than the epidermis (1-5mm) .Situated between the basement membrane zone and the subcutaneous layer. The functions areProtection; cushioning the deeper structures from mechanical injury; providing nourishment to the epidermis; playing an important role in wound healing.Layers of dermis are superficial papillary dermis;the deeper reticular dermis[23,24].

**Hypodermis:**

- The subcutaneous layer lying below the dermis; it consists largely of fat. It provides the main structural support for the skin, as well as insulating the body from cold and aiding shock absorption. It is interlaced with blood vessels and nerves[24]

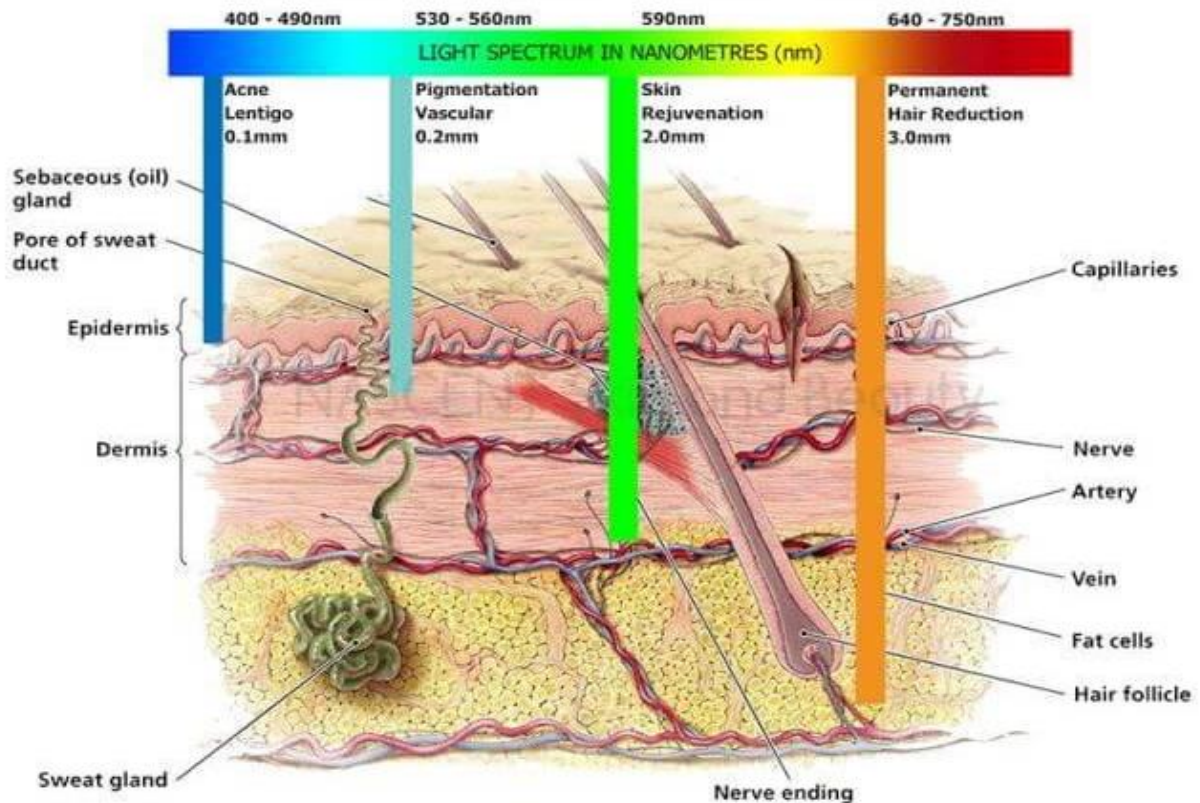

**Figure.5:** Medicallasers available for clinical PDT[35]

Firm skin can stretch and snap back into place easily. When skin loses this ability, it starts to sag. Saggy skin can happen almost anywhere on the body. Common areas where you might see saggy skin include:

- Eyelids
- Jowls
- Chin
- Throat
- Upper arms
- Stomach

**There are several causes of saggy skin. They include:**

### **Aging**

- As skin ages, it loses two important proteins manufactured in the dermis — elastin and collagen

### **Weight loss**

- Sagging skin is more likely to occur when weight loss is rapid, such as after bariatric surgery. In some instances, these weight loss procedures may result in large amounts of sagging, drooping skin that hangs on the body.

### **Pregnancy**

- Acquiring some degree of saggy, loose skin is common after pregnancy. Women who carry multiples, such as twins or triplets, may see more sagging skin around the abdomen than those who carry one baby. Maternal age may also play a role.

### **Illness**

- There are a few medical conditions that are marked by saggy skin. One of these is a very rare subtype of T-cell lymphoma known as granulomatous slack skin.
- People with this condition see a very gradual slackening of skin on the elbows and knees. Saggy skin caused by granulomatous slack skin does not typically respond well to treatment.
- Treatment options for saggy skin

### **Exercise**

- Saggy skin on the body caused by moderate weight loss or pregnancy can be improved through exercise.

### **Supplements**

- Oral supplements containing ingredients such as collagen and hyaluronic acid to help reduce age-related sagging skin

### **Lifestyle changes**

- Remaining hydrated, wearing sunscreen, and eliminating harmful habits like smoking can help your skin appear fresher and less saggy.
- Laser therapy. Several types of laser therapy treatments can help boost collagen production and improve overall skin tone. Most people see the best results after multiple treatments. Laser therapy can be beneficial for firming the upper arms and stomach, as well as other areas of the body.
- Laser resurfacing. This highly effective procedure also uses a laser, but is more invasive and has a longer recovery time, typically around two weeks laser removes the upper layers of skin and sends heat deep into the lower layers. It's sometimes referred to as laser peeling.
- Microfocused ultrasound (MFU). This technique sends heat deep into the skin's layers, supporting collagen production and lifting saggy skin. It can take several months before you start to see an improvement in your skin's firmness and elasticity. The results from ultrasound are not permanent and typically last about 1 year.

## **Surgical Treatment**

- Tummy tuck (abdominoplasty)
- Arm lift surgery (brachioplasty)
- Face lift
- Neck lift
- Lower body lift
- Upper body lift
- Medial thigh lift

## **Methods and Results**

### **1-PATIENT SELECTION:**

- The proper indication for Laser has been chosen.
- The patient understands that the majority of all Laser treatments we are performing at this time are considered off - label in the eyes of the FDA, although most have become the standard of care.
- Patients must understand fully the risks and benefits of this treatment.

### **1) Expected benefits and results:**

According to the Skin that would be treated for example in case of photorejuvenation would expect clearance and improvement and respond in 1-2 visits.

**2) Treatment Technique:**

- Discuss with patient all benefit and risks of this technique
- Assigned written consent
- Medical history
- Clean the face with a mild cleanser.
- Treated with four sessions, over 3- week intervals, using the 810- and 940-nm diode laser
- Two treatment processes were used to treat patients in each session. The first process was the painting technique with a smooth pulse mode. During the first process, eight passes were performed at the malar, nose, and chin areas; the settings were 8–10 J/cm<sup>2</sup> , 16–20 ms pulse duration, and 6 Hz. At the forehead area, four passes were performed, and the settings were 4–6 J/cm<sup>2</sup> , 10–12 ms pulse duration, and 6 Hz. An infrared thermometer device was used to maintain the temperature at close to 40–42 °C during this painting technique to stimulate the collagen remodeling that can make skin tighten. The second process included two passes of a staged pulse technique, with a skin rejuvenation mode, contact cooling, and cooling gel; the settings were 200–250 ms, 1 Hz, and a single pulse. The energy setting was allowed to adjust according to the patient’s skin type and specific susceptible areas. Basically, in patients with Fitzpatrick skin phototype type III, on the malar, nose, and chin area, 25–30 J/cm<sup>2</sup> was used, which was reduced to 15–20 J/cm<sup>2</sup> at the forehead area. In patients with Fitzpatrick skin phototype type IV, this value was reduced to 20–25 J/cm<sup>2</sup> and 10–15 J/cm<sup>2</sup> , respectively

**Complication:**

**Pain:** we can manage it by cold application

**Erythema:** use of Neocutis cream to reduce erythematic skin

**Phototoxicity:** patient may suffer off desquamation of the skin after several days, use of good skin miniaturization.

## **Discussion**

As mentioned before Diode laser in in range of mid infrared (810 -1200 nm ) has low water absorption and high penetration depth in human skin .we can use it in long pulse mode and moderate pulse mode with low parameters we have good result to stimulate collagen and elastin in the skin and in high power we will get good skin regeneration.

Several technique and parameters are published in many articles that concluded efficacy of diode laser in skin tightening and rejuvenation. Every day we have more advanced diode laser machine that has more options and ultra super short pulses for skin treatment. The laser practitioner must be aware about laser biophysics and laser tissue interactions in human skin to avoid any complication or tissue damage during treatment. a diode laser is a continuous wave laser and manufactures modification of this wave to make it a gated pulsed laser to give relaxation time and cooling for the skin between each pulses.

Laser safety protocol for all medical practitioners and for patient must be followed in laser room.

## **Conclusion**

Diode laser 810 to 1200 nm has good and significant results in skin tightening. The deeply penetrating wavelength imparts thermal injury to dermal collagen. Diode laser is a good choice for patients with minimal epidermal damage who desire improvement of mild to moderate rhytids without the postoperative morbidity common to the ablative laser systems. Additionally, the results in the treatment of active acne and atrophic scars are promising. Further study will elucidate optimal treatment parameters and protocols to attain the best clinical results.

---

## References

1. Zahra A-T. Impacts of laser energy doses in maintaining the shape and deformability of the red blood cell (morphological & physiological) in vitro. *Lett Appl NanoBioScience* 2020;9:875–9. <https://doi.org/10.33263/lianbs91.875879>.
2. Agostinis P, Berg K, Cengel KA, Foster TH, Girotti AW, Gollnick SO, et al. Photodynamic therapy of cancer: An update. *CA Cancer J Clin* 2011;61:250–81. <https://doi.org/10.3322/caac.20114>.
3. Hend Houssein, Suhaimi Jaafar Mohamad, Ali Z, Zahra, Al Timimi, Mustafa, Ismail A. Influence of Low Power He - Ne Laser Irradiation on Hemoglobin Concentration , Mean Cellular Volume of Red Blood Cell , and Mean Cellular Hemoglobin. *J Sains Kesihat Malaysia* 2011;9:9–13.
4. Medrado AR a P, Pugliese LS, Reis SR a, Andrade Z a. Influence of low level laser therapy on wound healing and its biological action upon myofibroblasts. *Lasers Surg Med* 2003;32:239–44. <https://doi.org/10.1002/lsm.10126>.
5. Bonnett R, Martínez G. Photobleaching of sensitisers used in photodynamic therapy. *Tetrahedron* 2001;57:9513–47. [https://doi.org/10.1016/S0040-4020\(01\)00952-8](https://doi.org/10.1016/S0040-4020(01)00952-8).
6. Ibbotson SH. An overview of topical photodynamic therapy in dermatology. *Photodiagnosis Photodyn Ther* 2010;7:16–23. <https://doi.org/10.1016/j.pdpdt.2009.12.001>.
7. Banerjee SM, MacRobert AJ, Mosse CA, Periera B, Bown SG, Keshtgar MRS. Photodynamic therapy: Inception to application in breast cancer. *The Breast* 2017;31:105–13. <https://doi.org/10.1016/j.breast.2016.09.016>.
8. Al-Timimi J. Investigation of the semiconductor laser beam propagation through air and pure water (stable and turbulence). *Iraqi Laser Sci J* 2019;1:7–14.
9. Houssein HAA, Jaafar MS, Ali Z, Timimi ZA, Mustafa FH. Study of hematocrit in relation with age and gender using low power helium - Neon laser irradiation. *IFMBE Proc.*, vol. 35 IFMBE, 2011, p. 463–6. [https://doi.org/10.1007/978-3-642-21729-6\\_117](https://doi.org/10.1007/978-3-642-21729-6_117).

- 
10. Nomoto T, Nishiyama N. Photodynamic therapy. *Photochem. Biomed. Appl. From Device Fabr. to Diagnosis Ther.*, 2018, p. 301–13. [https://doi.org/10.1007/978-981-13-0152-0\\_11](https://doi.org/10.1007/978-981-13-0152-0_11).
  11. Barakat DA, Al-Abbas G, Al-Timimi ZJMA. Utilization of diode laser therapy with wavelength 904nm during pregnancy: A preliminary study. *Iraqi Laser Sci J (ILSJ)/ Wwww.ilsj-Online.org* 2019;1:15–20.
  12. Zahra Al Timimi, Mohamad Suhaimi Jaafar MZMJ. Comparison between low level laser therapy and exercise for treatment of chronic low back pain. *Indian J Physiother Occup Ther - An Int J* 2010;4:102–4.
  13. Eber AE, Perper M, Verne SH, Magno R, ALOmair IAO, ALHarbi M, et al. Photodynamic therapy. *Lasers dermatology Med. dermatologic Appl.*, 2018, p. 261–73. [https://doi.org/10.1007/978-3-319-76118-3\\_16](https://doi.org/10.1007/978-3-319-76118-3_16).
  14. Dąbrowski JM, Arnaut LG. Photodynamic therapy (PDT) of cancer: from local to systemic treatment. *Photochem Photobiol Sci* 2015;14:1765–80. <https://doi.org/10.1039/C5PP00132C>.
  15. Baratto L, Calzà L, Capra R, Gallamini M, Giardino L, Giuliani A, et al. Ultra-low-level laser therapy. *Lasers Med Sci* 2011;26:103–12. <https://doi.org/10.1007/s10103-010-0837-2>.
  16. Thornton MJ. Human skin. *Menopause* 2016;23:119–20. <https://doi.org/10.1097/gme.0000000000000589>.
  17. Skin H. Studies on the Structure and Function of. *Ski Res* 1959;1:127–32. <https://doi.org/10.11340/skinresearch1959.1.127>.
  18. Dormont L, Bessière JM, Cohuet A. Human Skin Volatiles: A Review. *J Chem Ecol* 2013;39:569–78. <https://doi.org/10.1007/s10886-013-0286-z>.
  19. Nicol NH. Anatomy and physiology of the skin. *Dermatol Nurs* 2005;17:62. [https://doi.org/10.4324/9780203450505\\_chapter\\_1](https://doi.org/10.4324/9780203450505_chapter_1).
  20. Wysocki AB. Skin anatomy, physiology, and pathophysiology. *Nurs Clin North Am* 1999;34.
-

- 
21. Desaix P. Layers of the Skin – Anatomy and Physiology. OpenStax 2018.
  22. Singh C. Skin anatomy and physiology. *Wound Care Made Incred. Vis.*, 2018, p. 1–10. [https://doi.org/10.5005/jp/books/12699\\_2](https://doi.org/10.5005/jp/books/12699_2).
  23. Ribeiro CS, Leal F, Jeunon T. *Skin Anatomy, Histology, and Physiology*, 2017, p. 1–12. [https://doi.org/10.1007/978-3-319-20250-1\\_1-1](https://doi.org/10.1007/978-3-319-20250-1_1-1).
  24. Casey G. Physiology of the skin. *Nurs Stand* 2002;16. <https://doi.org/10.7748/ns2002.05.16.34.47.c3193>.
  25. Zahra A-T. A Comparative Study of Determination the Spectral Characteristics of Serum Total Protein Among Laser System and Spectrophotometric: Advantage and Limitation of Suggested Methods. *Curr Anal Chem* 2019;15:583–90. <https://doi.org/10.2174/1573411014666180531092053>.
  26. Zahra AT. Technological advancements to reduce the influence of absorption and scattering on the optical imaging. *Bangladesh Med Res Counc Bull* 2020;46:64–5. <https://doi.org/10.3329/bmrcb.v46i1.47472>.
  27. Gregory RO. Laser physics and physiology. *Clin Plast Surg* 1998;25:89–93. <https://doi.org/10.1097/00006527-199701730-00003>.
  28. Zahra AT. Biological Effects of Yellow Laser-Induced of Cell Survival: Structural DNA Damage Comparison is Undergoing Ultraviolet Radiation Photocoagulation. *Int J Eng Res Gen Sci* 2014;2:544–8. <https://doi.org/doi=10.1.1.650.4677>.
  29. Mustafa FH, Jaafar MS, Ismail AH, Omar AF, Timimi ZA, Houssein HAA. Red diode laser in the treatment of epidermal diseases in PDT. *World Acad Sci Eng Technol* 2010;46:779–82. <https://doi.org/10.5281/zenodo.1057095>.
  30. Diam WA, Zahra A-T. Characterization and fabrication of Nd:YVO<sub>4</sub> disc laser system. *AIP Conf. Proc.*, vol. 2123, American Institute of Physics Inc.; 2019, p. 20009. <https://doi.org/10.1063/1.5116936>.

- 
31. Jassim Mohammed Al Timimi Z, Saleem Ismail Alhabeel M. Laser Dental Treatment Techniques. *Prev. Detect. Manag. Oral Cancer*, IntechOpen; 2019, p. 1–16. <https://doi.org/10.5772/intechopen.80029>.
32. Houssein HAA, Jaafar MS, Ali Z, Timimi ZA, Mustafa FH. Study of Hematocrit in Relation with Age and Gender Using Low Power Helium - Neon Laser Irradiation. Osman N.A.A., Abas W.A.B.W., Wahab A.K.A., Ting HN. 5th Kuala Lumpur Int. Conf. Biomed. Eng., vol. 35, 2011, p. 463–6. [https://doi.org/10.1007/978-3-642-21729-6\\_117](https://doi.org/10.1007/978-3-642-21729-6_117).
33. Szeimies RM, Karrer S, Abels C, Landthaler M, Elmets CA. Photodynamic therapy in dermatology. *Dermatological Phototherapy and Photodiagnostic Methods*, 2009, p. 241–80. [https://doi.org/10.1007/978-3-540-36693-5\\_11](https://doi.org/10.1007/978-3-540-36693-5_11).
34. Lim CK, Heo J, Shin S, Jeong K, Seo YH, Jang WD, et al. Nanophotosensitizers toward advanced photodynamic therapy of Cancer. *Cancer Lett* 2013;334:176–87. <https://doi.org/10.1016/j.canlet.2012.09.012>.
35. Allison RR, Sibata CH. Oncologic photodynamic therapy photosensitizers: A clinical review. *Photodiagnosis Photodyn Ther* 2010;7:61–75. <https://doi.org/10.1016/j.pdpdt.2010.02.001>.
36. Brancaleon L, Moseley H. Laser and non-laser light sources for photodynamic therapy. *Lasers Med Sci* 2002;17:173–86. <https://doi.org/10.1007/s101030200027>.
37. Allison RR, Moghissi K. Photodynamic Therapy (PDT): PDT Mechanisms. *Clin Endosc* 2013;46:24. <https://doi.org/10.5946/ce.2013.46.1.24>.
38. Higgins SLH, Brewer KJ. Designing Red-Light-Activated Multifunctional Agents for the Photodynamic Therapy. *Angew Chemie Int Ed* 2012;51:11420–2. <https://doi.org/10.1002/anie.201204933>.
39. Chen TC, Huang L, Liu CC, Chao PJ, Lin FH. Luminol as the light source for in situ photodynamic therapy. *Process Biochem* 2012;47:1903–8. <https://doi.org/10.1016/j.procbio.2012.06.025>.
-

- 
40. MacCormack MA. Photodynamic Therapy. *Adv Dermatol* 2006;22:219–58. <https://doi.org/10.1016/j.yadr.2006.09.008>.
41. Zahra'a A-T, Zahra ' A-T. Assessment of the impacts of 830 nm Low Power Laser on Triiodothyronine (T3), Thyroxine (T4) and the Thyroid Stimulating Hormone (TSH) in the Rabbits. *J Med Sci Clin Res* 2014.
42. Stables GI, Ash DV. Photodynamic therapy. *Cancer Treat Rev* 1995;21:311–23. [https://doi.org/10.1016/0305-7372\(95\)90035-7](https://doi.org/10.1016/0305-7372(95)90035-7).
43. Yasumoto M, Shimoda T, Tsubouchi R, Kawana S. Photodynamic Therapy. *Nishinohon J Dermatology* 2009;71:201–5. <https://doi.org/10.2336/nishinohonhifu.71.201>.
44. Chandran R, Denis TGS, Vecchio D, Avci P, Sadasivam M, Hamblin MR. Photodynamic Therapy. *Photonics Sci. Found. Technol. Appl.*, vol. 4, 2015, p. 413–67. <https://doi.org/10.1002/9781119011804.ch10>.
45. Zahra A-T. A Comparative Study of Determination the Spectral Characteristics of Serum Total Protein Among Laser System and Spectrophotometric: Advantage and Limitation of Suggested Methods. *Curr Anal Chem* 2018;14:1–8. <https://doi.org/10.2174/1573411014666180531092053>.
46. Zahra A-T. Impacts of laser energy doses in maintaining the shape and deformability of the red blood cell (morphological & physiological) in vitro. *Lett Appl NanoBioScience* 2020;9:875–9. <https://doi.org/10.33263/lianbs91.875879>.
47. Rkein AM, Ozog DM. Photodynamic therapy. *Dermatol Clin* 2014;32:415–25. <https://doi.org/10.1016/j.det.2014.03.009>.
48. Min PK, Goo BL. 830 nm light-emitting diode low level light therapy (LED-LLLT) enhances wound healing: A preliminary study. *Laser Ther* 2013;22:43–9. <https://doi.org/10.5978/islsm.13-OR-06>.
49. Smith RP, Hahn SM, Johnstone PAS. Photodynamic therapy. *Curr Probl Cancer* 2002;26:67–108. <https://doi.org/10.1067/mcn.2002.125408>.
-

- 
50. AL-TimimiZahra a. Biological Effects of Yellow Laser-Induced of Cell Survival: Structural DNA Damage Comparison is Undergoing Ultraviolet Radiation Photocoagulation. *Int J Eng Res Gen Sci* 2014;2:544–8. <https://doi.org/doi=10.1.1.650.4677>.
51. Al Timimi Z, Jaafar MSM, Zubir M, Jafri M, Zahra Al Timimi, Jaafar MSM, et al. Photodynamic therapy and Green Laser blood Therapy. *Glob J Med Res* 2011;11:22–8. <https://doi.org/10.17406/gjmra>.
52. Muragaki Y, Maruyama T, Nitta M, Ikuta S, Iseki H, Saito T. Photodynamic therapy. *Neurol Surg* 2015;43:583–92. <https://doi.org/10.11477/mf.1436203082>.
- 53 Alster TS, Lupton JR. An overview of cutaneous laser resurfacing. *Clin Plast Surg* 2001;28:37–52.
54. Alster TS. Cutaneous resurfacing with CO<sub>2</sub> and erbium:YAG lasers: perioperative, intraoperative, and postoperative considerations. *Plast Reconstr Surg* 1999;103:619–32.
55. Nanni CA, Alster TS. Complications of carbon dioxide resurfacing.
56. Alster TS, Lupton JR. Are all infrared lasers equally effective in skin. *Semin Cutan Med Surg* 2002;21:274–9.
57. Bjerring P, Clement M, Heikerndorff L, et al. Selective non-ablative wrinkle reduction by laser. *J Cutan Laser Ther* 2000;29:15.
58. Rostan EF, Bowes LE, Iyer S, Fitzpatrick RE. A double-blind, side-by-side comparison study of low fluence long pulse dye laser to coolant treatment for wrinkling of the cheeks. *J Cosmet Laser Ther* 2001;3:129–36.
59. Goldberg DJ, Cutler KB. Nonablative treatment of rhytids with intense pulsed light. *Lasers Surg Med* 2000;26:196–200.
60. Goldberg DJ, Silapunt S. Histologic evaluation of a Q-switched Nd:YAG laser in the nonablative treatment of wrinkles. *Dermatol Surg* 2001;27:744–6.
-

61. Goldberg DJ, Rogachefsky AS, Silapunt S. Non-ablative laser treatment of facial rhytides. A comparison of 1450-nm diode laser treatment with dynamic cooling as opposed to treatment with dynamic cooling alone. *Lasers Surg Med* 2001;30:79–81.
62. Tanzi EL, Alster TS. Treatment of facial rhytides with a 1,450-nm diode laser: a controlled clinical and histologic study. *Dermatol Surg* 2003;29:124–8.

